

Instructions

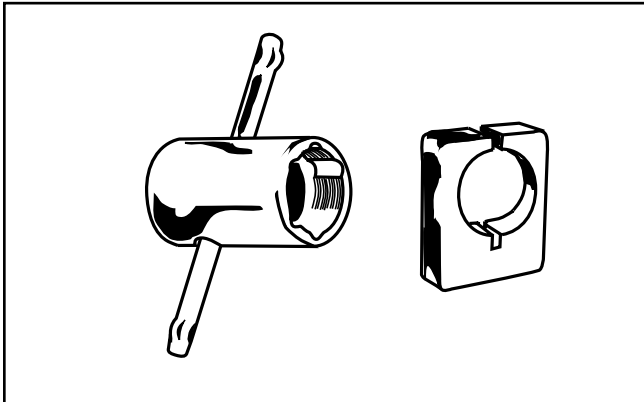

Mortise Cylinder Die & Holder

No. CLD-6



DIRECTIONS:

1. Place mortise cylinder through holder hole until holder butts against cylinder neck. See Fig. 1.
2. Tighten vise jaws against side flats of holder to grip cylinder securely. Put several drops of oil on cylinder threads. See Fig. 2.
3. Place die on cylinder and begin to re-cut threads. Die must be started straight or "crossed threads" will result. See Fig. 3.

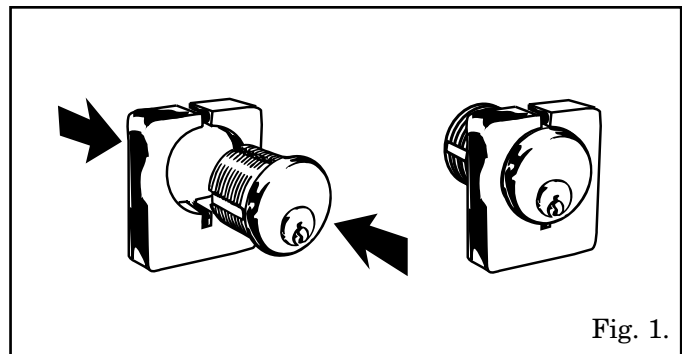

Fig. 1.

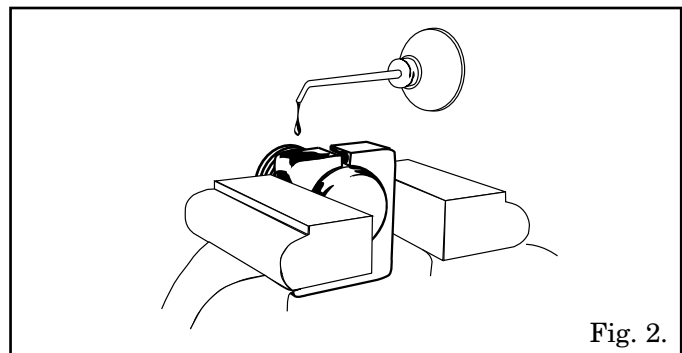

Fig. 2.

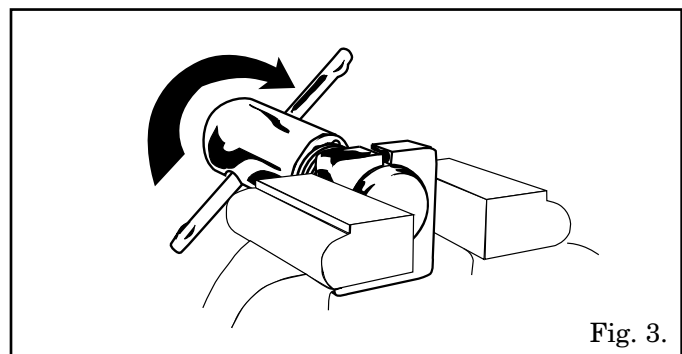

Fig. 3.

032300

35T00-064-00