

Instructions

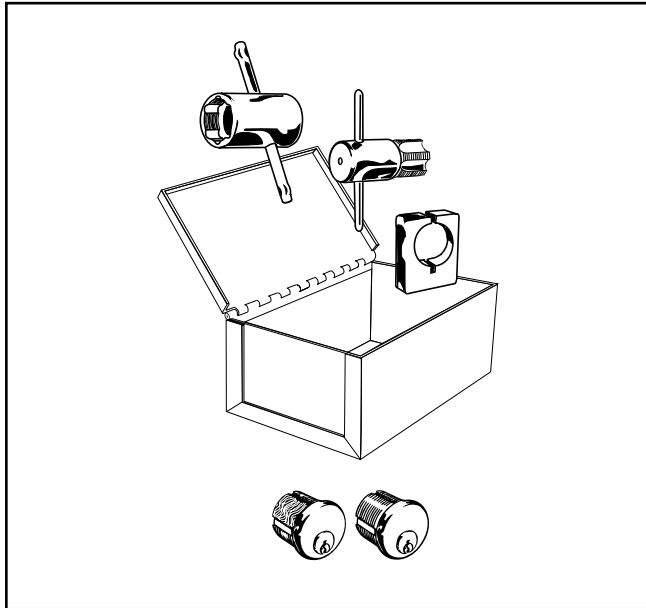

Mortise Cylinder Lock Tap & Die Set

No. CLTD-5



CYLINDER TAP:

1. Place lock case in a vise (if not in the door). Put several drops of oil on the cylinder threads. Enter tap straight into the cylinder hole and turn one half-turn counterclockwise (this will assure you of proper cutting alignment). While carefully holding tap straight, turn clockwise slowly and tap will re-thread stripped or worn cylinder hole. See Fig. 1.

CYLINDER DIE & HOLDER:

1. Place mortise cylinder through holder hole until holder butts against cylinder neck. See Fig. 2.
2. Tighten vise jaws against side flats of holder to grip cylinder securely. Put several drops of oil on cylinder threads.
3. Place die on cylinder and begin to re-cut threads. Die must be started straight or "crossed threads" will result.

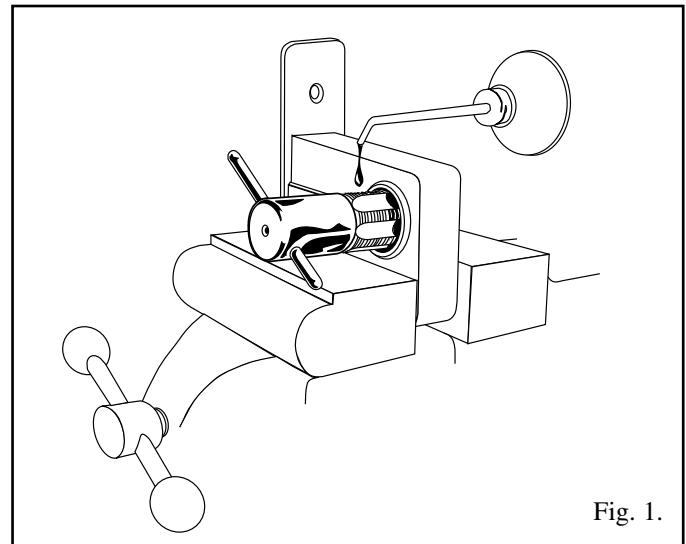

Fig. 1.

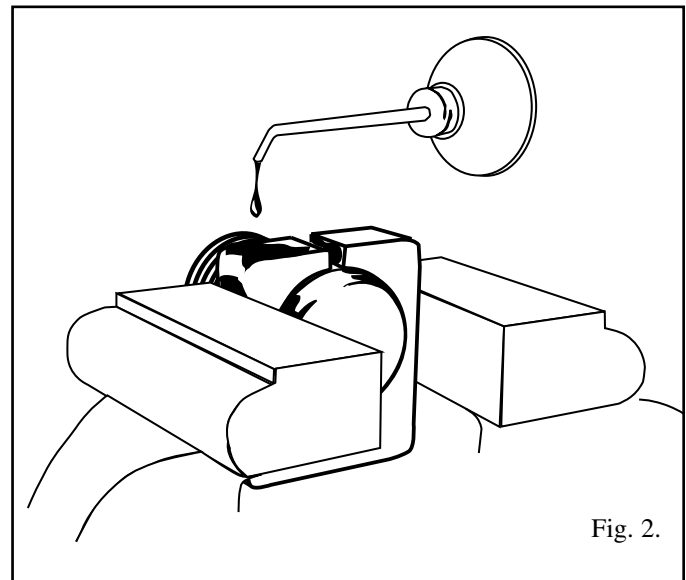

Fig. 2.

032800

35T00-065-00