

# Instructions

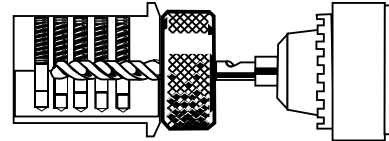

## Cylinder Drill Jig

No. CDJ-1

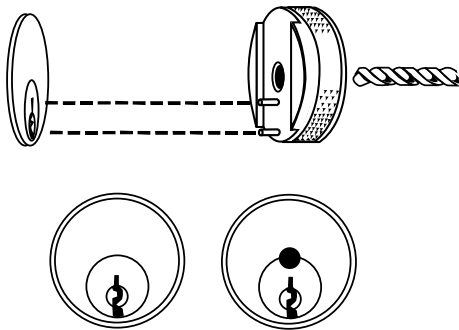

Place the roll pins of the jig into the top and bottom portion of the keyway as shown. Keep the drill bit perpendicular to the face of the cylinder while drilling. Remove as much of the broken pins and springs as possible. Insert a screwdriver into the keyway and turn to unlock.

040500 35T00-069-00

© 2000 • HPC, Inc. • Schiller Park, IL • 60176 • USA • [www.hpcworld.com](http://www.hpcworld.com)

# Instructions



## Cylinder Drill Jig

No. CDJ-1

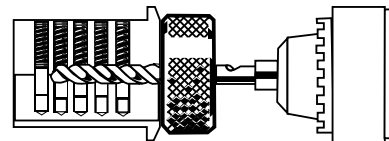
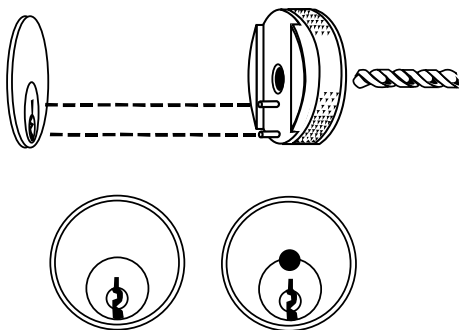

Place the roll pins of the jig into the top and bottom portion of the keyway as shown. Keep the drill bit perpendicular to the face of the cylinder while drilling. Remove as much of the broken pins and springs as possible. Insert a screwdriver into the keyway and turn to unlock.

040500 35T00-069-00

© 2000 • HPC, Inc. • Schiller Park, IL • 60176 • USA • [www.hpcworld.com](http://www.hpcworld.com)