

Instructions

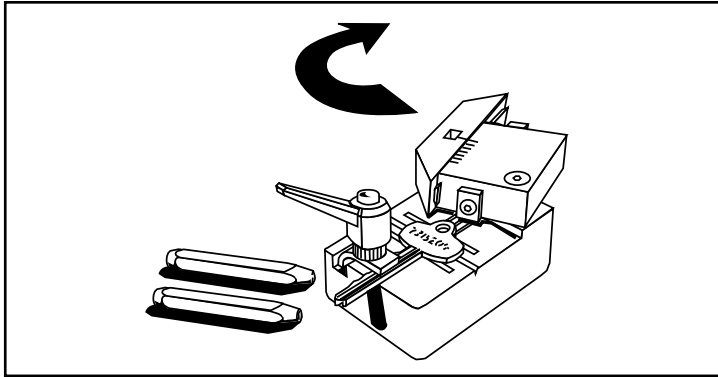

Stamp Aligner™

No. SA-7



HPC's Stamp Aligner™ solves the problems that locksmiths have while stamping numbers on keys. It holds standard $\frac{3}{32}$ " and $\frac{1}{8}$ " number and letter die stamps so that figures may be stamped on keys in an exact straight line with exact spacing between figures. When the die stamps are all struck with the same force, the result is a key that looks like it was factory stamped. HPC's new Stamp Aligner makes stamping keys safer and easier. Plus, it can use the die stamps that many locksmiths already have.

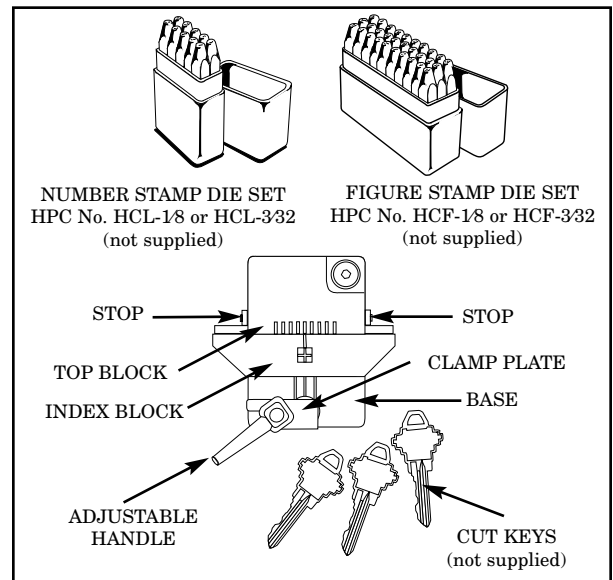

1. Swivel the top block to load/unload position.
2. Loosen the clamp plate counterclockwise.
3. Insert the key or object to be stamped using line-up markings.
4. Swivel the clamp plate over the key and tighten clockwise.
5. Lift and move handle out of the way.

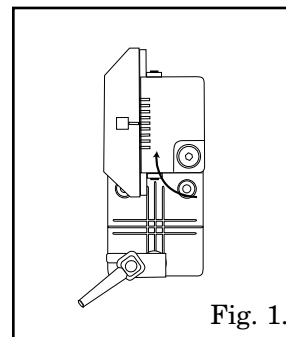

Fig. 1.

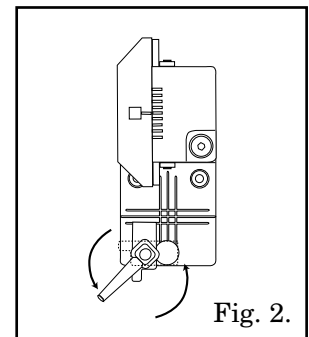

Fig. 2.

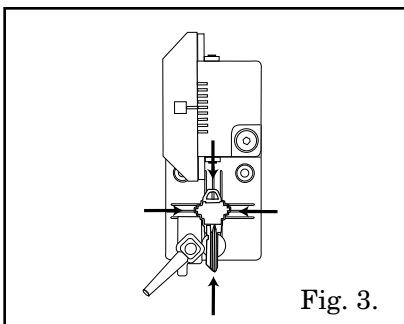

Fig. 3.

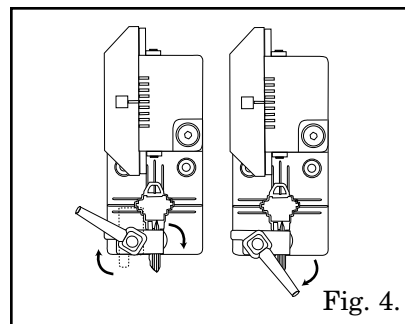

Fig. 4.

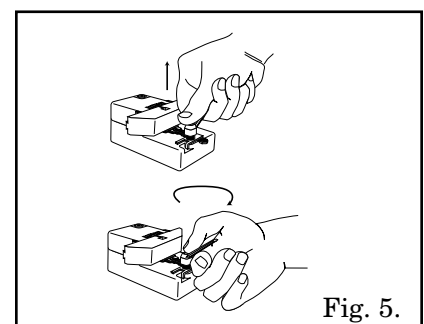

Fig. 5.

020800 35T00-197-00

(continued)

SA-7 instructions (continued)



6. Swivel the top block into the stamping position.
7. Move the index block to the first detent position.
8. Always insert the stamp with the notch facing you.
9. NOTE: If your stamps do not fit due to “mushrooming” at head, you must file them back to their original shape.
10. Strike with hammer to stamp key.
11. Index and stamp all.
12. Swivel to remove key.

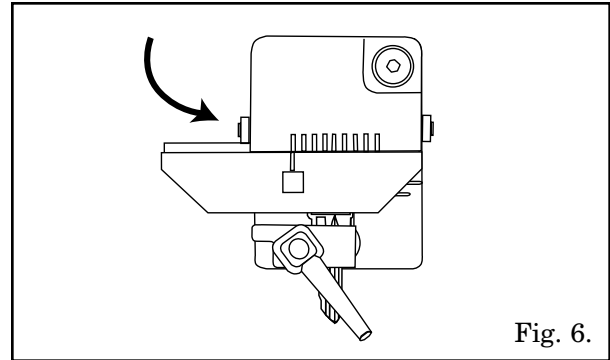

Fig. 6.

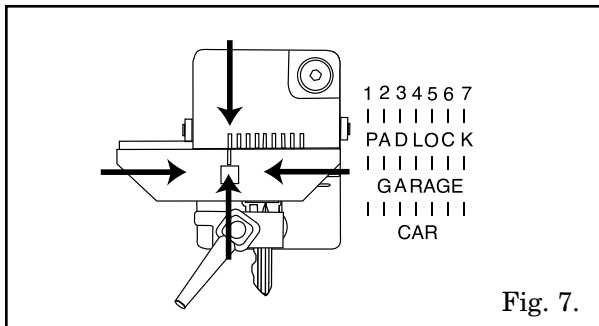

Fig. 7.

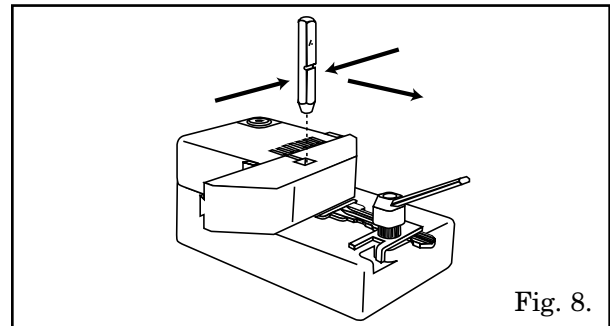

Fig. 8.

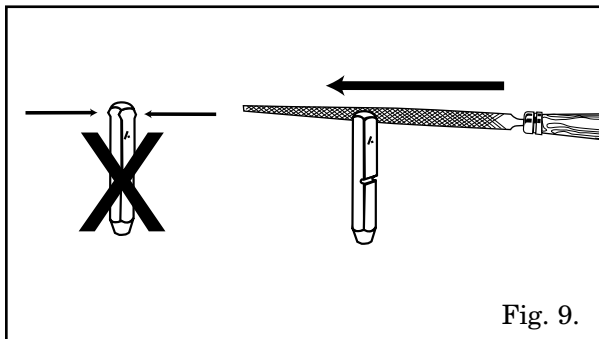

Fig. 9.

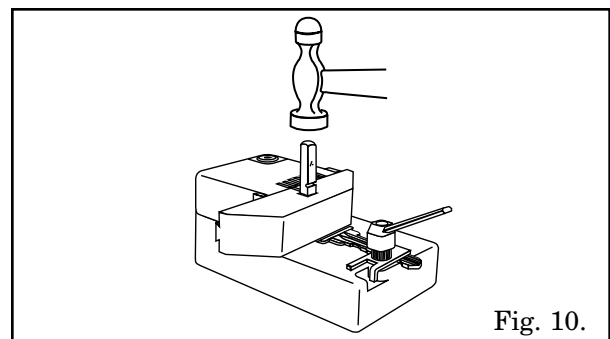

Fig. 10.

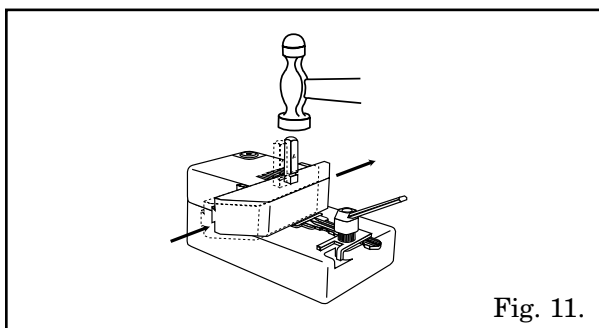

Fig. 11.

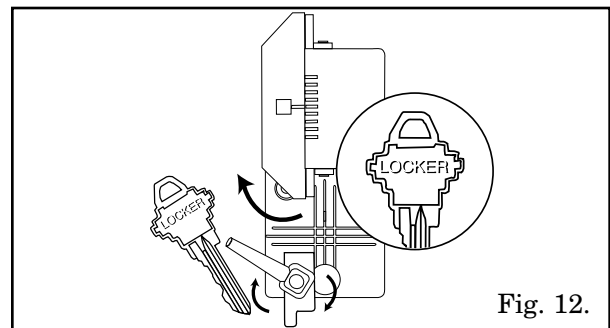

Fig. 12.